



FISICA



DTRA



CTEIP

FAST MARX DESIGN AND TESTING AT DTRA WEST COAST FACILITY QUAD-EAGLE SIMULATOR

Fabrizio Ambrosini*, David Phipps, Yoko Kawai Parker, Rick Spielman, James Mamood, Peter Sincerny – FISICA, Inc.
Pamela Gordon, Jacob Calkins, Steven Seiler – Defense Threat Reduction Agency

2025 IEEE International Pulsed Power Conference

➤ Outline:

- Motivation
- Development of the Fast Marx technology
- Fast Marxes for Quad-EAGLE (QE)
- QE Module Testing and simulations
- QE Trigger System
- Conclusions and future outlook

➤ Motivation:

Defense Threat Reduction Agency (DTRA) has secured a contract through the CTEIP program to upgrade three facilities. Two of the Nuclear Effects Simulator are located at the West Coast Facility- Fisica ATI in San Leandro CA

1. Double-EAGLE upgraded to Quad Eagle

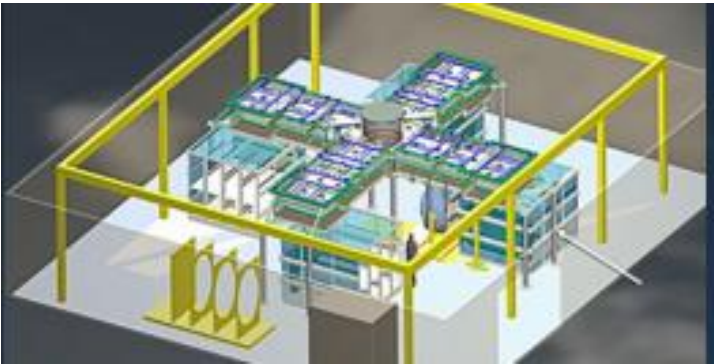

- Double-EAGLE (DE) is the largest nuclear-weapons-effects x-ray test facility in the DoD complement of simulators and has not been refurbished since completion in 1983.
- QE is designed to replace Double Eagle, ensuring increased capabilities for the Testing community:
 - High dose rate over a large range of test areas
 - Spectral range capabilities from UV to hot X-rays
 - Electron Beam capabilities

2. PITHON upgraded to PITHON II



- PITHON facility is more than 40 years old. New contract is to upgrade the facilities, controls, and infrastructure to develop and deliver new machines with customer focus on reproducibility and reliability at the same or lower cost per shot.
- Quad Eagle is preparing for customer acceptance test, and PITHON II is in the design phase

➤ Motivation:

We chose to employ Fast Marx Generators in QE because of several reasons:

- **Eliminates the need for storing energy in a large water transfer capacitor (TC).** The present two-module DE uses two, standard Marx generators per module. The charging time of the Marxes into the TC is $\sim 1.5 \mu\text{s}$. The present water-filled TC is $\sim 175\text{-ns}$ long and has an average impedance of 1.66Ω .
- **Eliminates the two electrically triggered gas switches (TGS).** Each TC is discharged via a single, electrically-triggered cascade gas switch (in water). The output pulse then charges the CPL in $\sim 300 \text{ ns}$. TGS jitter was the weak element of DE, highly affecting machine operation.

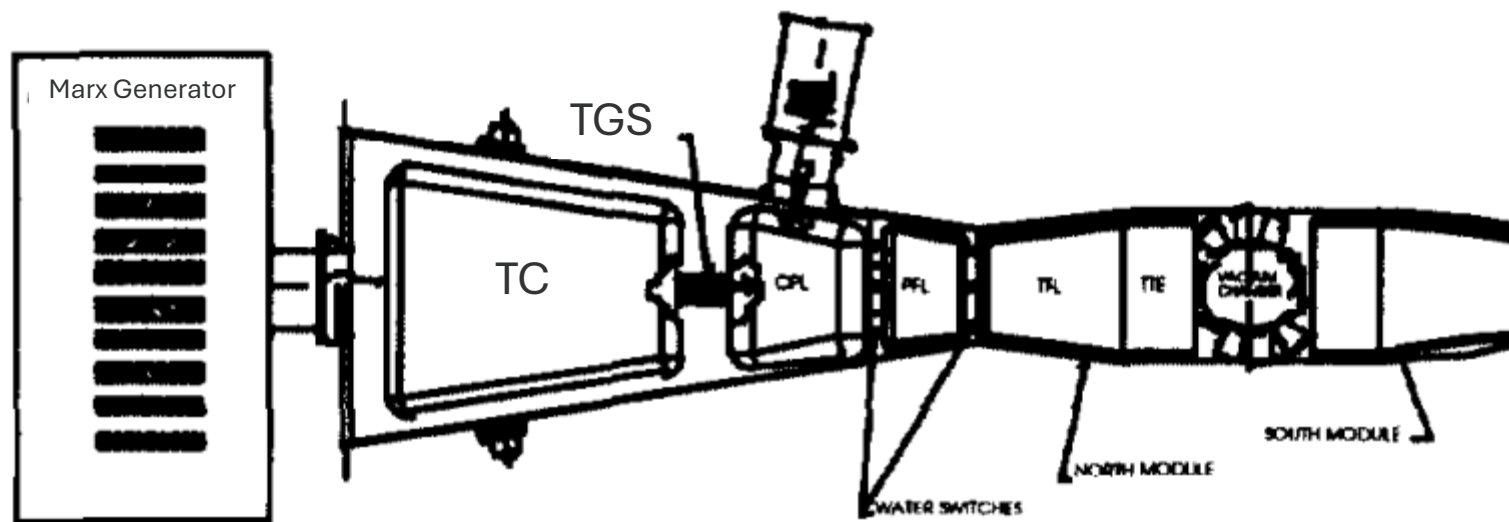

IMPROVEMENT ON DOUBLE-EAGLE MACHINE SYNCHRONIZATION IN BOTH NEGATIVE AND POSITIVE MODES OF OPERATION*

S. K. Lam, J. Banister, B. Christensen, R. Schneider, B. Whitton, S. Wong (Maxwell Physics International); L. Pressley (Defense Threat Reduction Agency); S. Seiler (Alme and Associates)

➤ Motivation:

- **Footprint.** This new FMG technology will provide the capability to build Terawatt size machines in a smaller form factor.

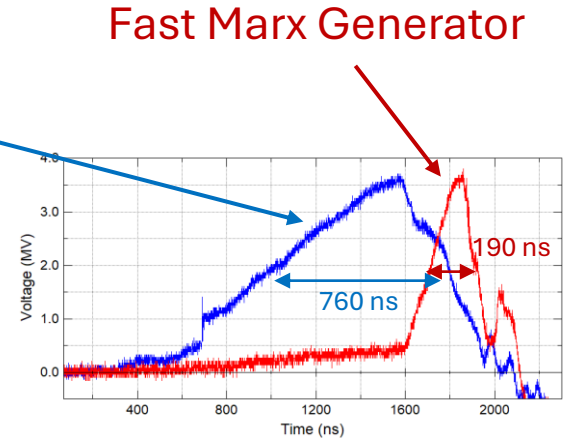
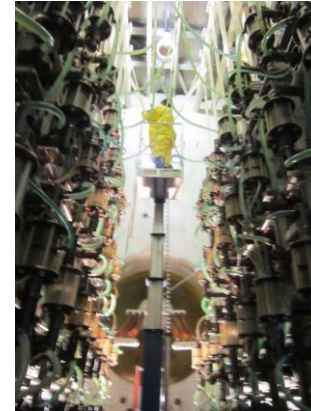

- **Commercial availability of low inductance Switches and Capacitors.**
 - The basic building blocks for FMG (Fast Marx Generator) driven machines are a low inductance Marx switches and capacitors. These components are configured in a low-inductance FMG stage and then stacked in series to form a unit for the voltage required. In addition a number of units combined in parallel reduces the system inductance and increases the stored output energy.
 - The Fast Marx design upgrade is due to two developed technologies. The first is the change in manufacturing technology of capacitors over the past 20 years has reduced the volume and weight by factor of 3 to 4 and decreased the internal resistance and inductance of each capacitor. The second is a robust 200 kV electrically triggered gas switch developed here at FISICA ATI.

Development of the Fast Marx Technology:

Fast Marx technology has been developed by FISICA (formerly Maxwell Physics International) from the 90s:

2004



Fast Marx Research

- Measured inductance of four-stage Marx demonstrates the design goal of $\sqrt{LC} < 300$ ns

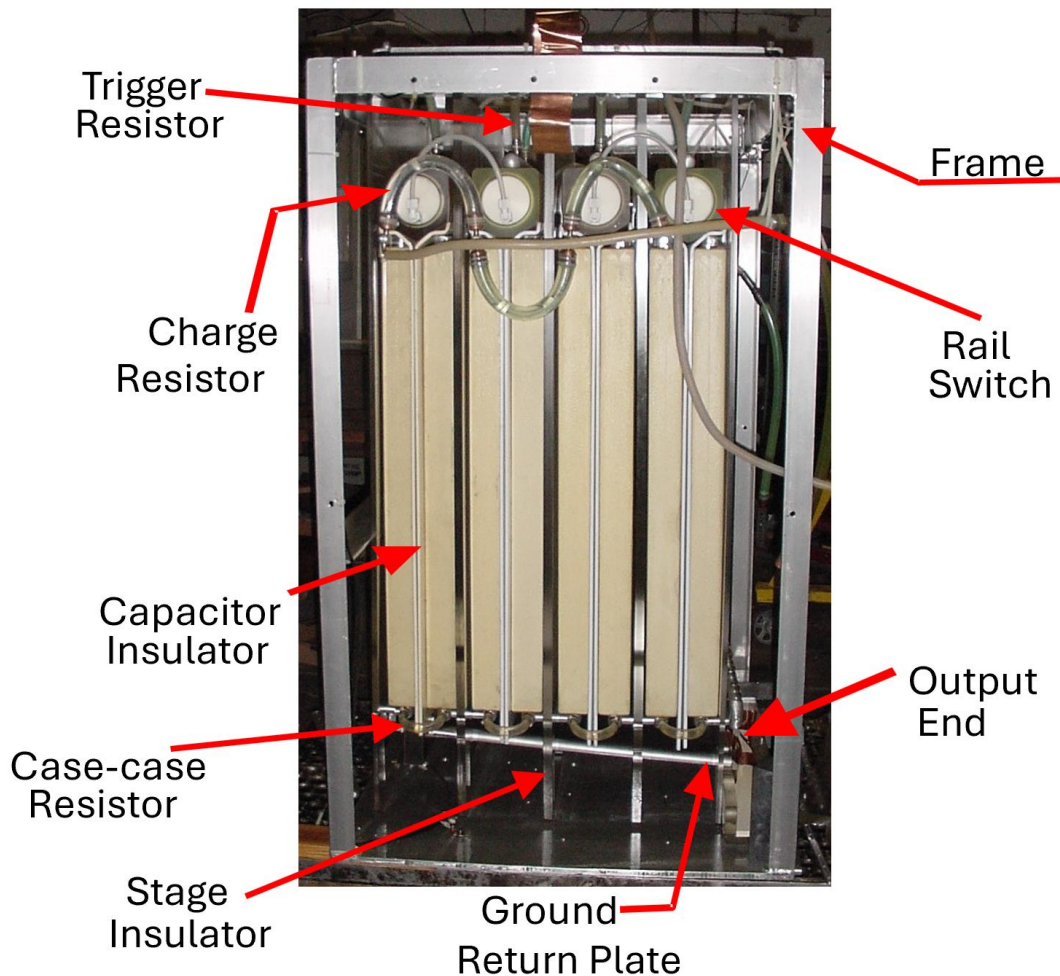

Short-circuit Voltage and Current Waveforms

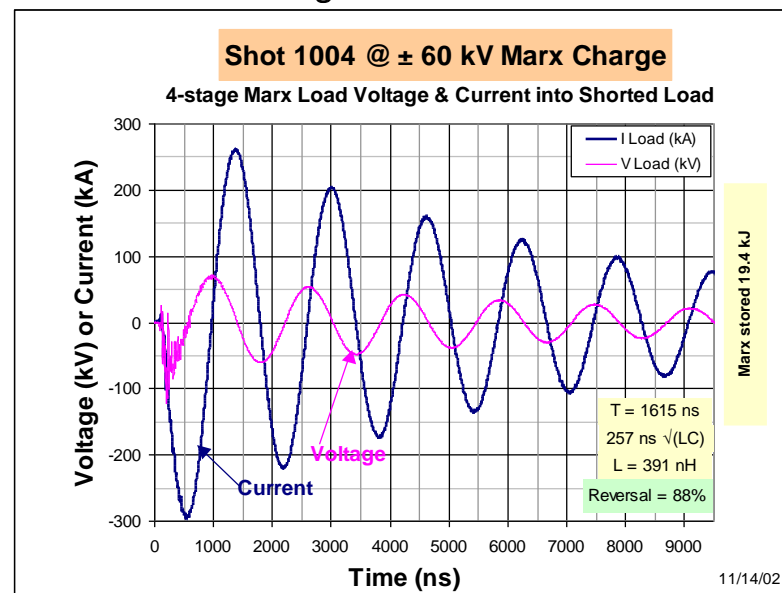

Configuration*	Marx Inductance (L)	\sqrt{LC}	Ringing Period: $2\pi \sqrt{LC}$
Four-stage Fast Marx shorted at output terminals	391 nH	257 ns	1615 ns

* Marx erected capacitance $C = 1.35 \mu\text{F}/8 = 169$ nF

Development of the Fast Marx Technology:

Fast Marx technology has been developed by FISICA (formerly Maxwell Physics International) from the 90s:

2004



Fast Marx
Research

2010

Fast Marx concept
and components

Short Pulse Gamma (SPG) Marx:

- 10 stages
- 1.5 MV, 0.07 MA
- 0.01 MJ of stored energy
- 0.08 TW facility

2016 Short Pulse Gamma (SPG) User Facility

- Important capability for the customers at WCF
- Critical Technology for New Simulators.

Development of the Fast Marx Technology:

Fast Marx technology has been developed by FISICA (formerly Maxwell Physics International) from the 90s:

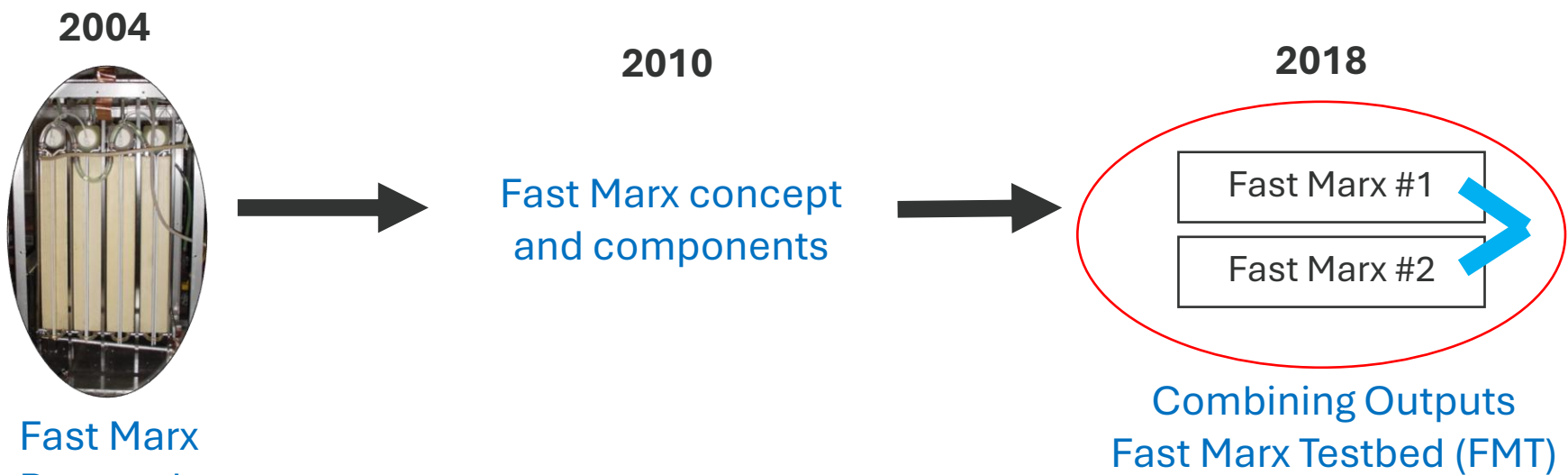

- Sub-Marxes are independent with their own resistive loads
- QE Risks reduction started during FMT test:
 - Capacitor reliability
 - Switch lifetime and prefire rates
 - Fast Marx scalability (current): Sub-Marx jitter timing
 - Fault modes were investigated

Development of the Fast Marx Technology:

Fast Marx technology has been developed by FISICA (formerly Maxwell Physics International) from the 90s:

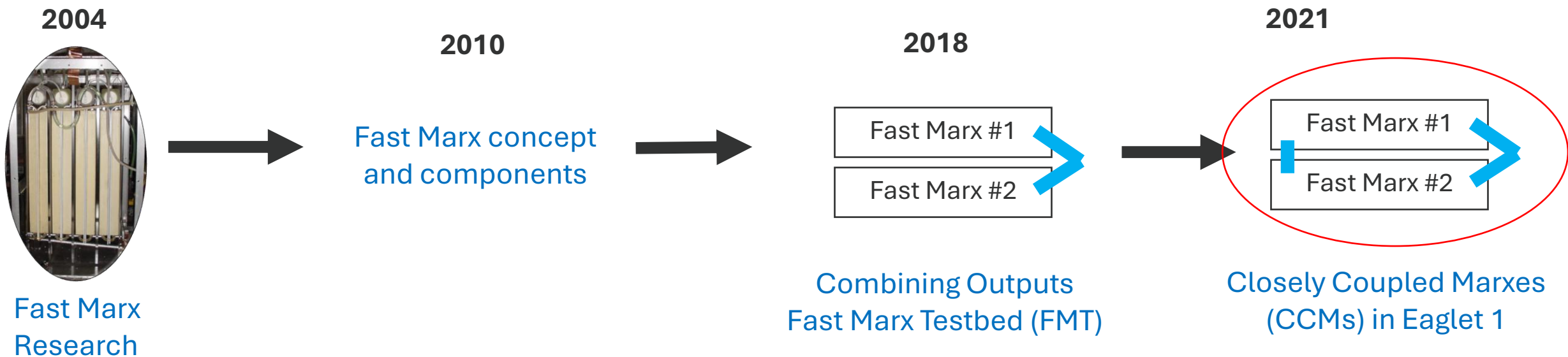

- One ground side of a low voltage stage on each Fast Marx is connected together using a sub-Marx Crossover cable that effectively Closely Couple the Marxes.
- Tested different coupling configurations along the two sub-Marxes optimizing the timing jitter between the two outputs.
- Eaglet I experimentally showed that the two sub-Marxes fire together, even in an event of Pre-fire, when they are Closely Coupled together.

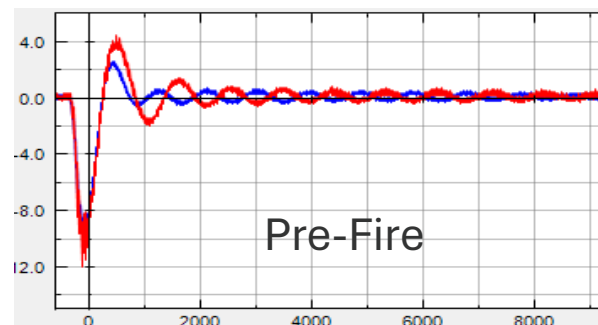
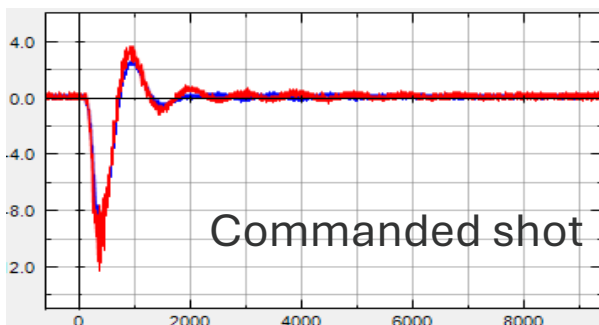

➤ Development of the Fast Marx Technology: CCM in Eaglet 2

Fast Marx technology has been developed by FISICA (formerly Maxwell Physics International) from the 90s:

2004



2022

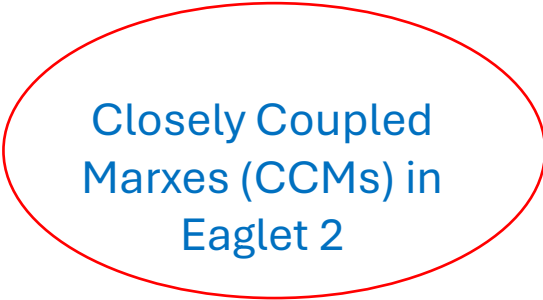

Closely Coupled
Marxes (CCMs) in
Eaglet 2

Fast Marx
Research

**Single sub-Marx
characteristics:**

- Marx consist of 20 bi-polar charged stages.
- Every Stage does have a FISICA 200-kV switch
- Each half-stage is composed of two Capacitor Specialist Incorporated (CSI) (<http://csicapacitors.com/>)
100kV, 160nF, Capacitors in parallel
- Demonstrates the design goal of $\sqrt{LC} < 300$ ns
- Total Energy stored: 46 kJ

➤ Development of the Fast Marx Technology: CCM in Eaglet 2

Solid State Resistors

- During the previous work for the design of the FMT, the solid state resistors were tested for voltage hold-off and survivability in a vertical orientation. However, with the resistors in the horizontal orientation as originally implemented in FMT, air bubbles became trapped between the center tie rod and the ceramic resistor components.

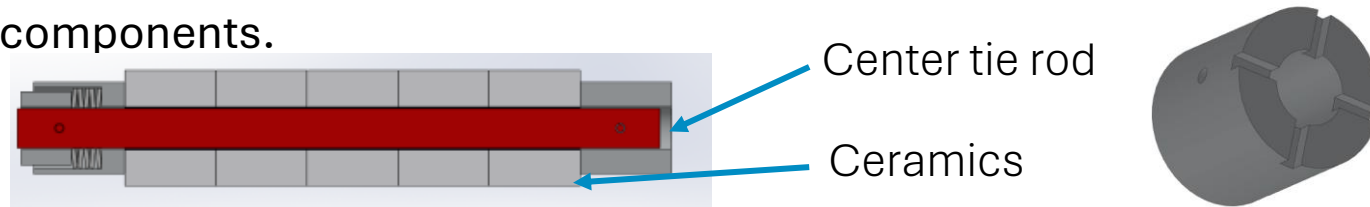

- In collaboration with the resistor manufacturer, slots were designed in the resistor assembly to relieve the bubbles with only slight angles needed. The design of one end of the trigger resistor holder was also modified to keep the trigger resistors at enough of an angle to allow bubbles to be relieved.
- Eliminate in the mechanical design any flat surface or areas where air can get trapped
- Internal standard operation after oil processing: hold voltage to stir oil and get rid of bubbles in critical areas. During the DC charging of the fast Marx, oil will be stirred due to the electrostatic charge that builds within the oil itself. This stirring can be used by holding voltage at low levels to dislodge bubbles that may have been trapped in difficult to reach parts of the Marx.

Development of the Fast Marx Technology: CCM in Eaglet 2

FISICA 200-kV switches

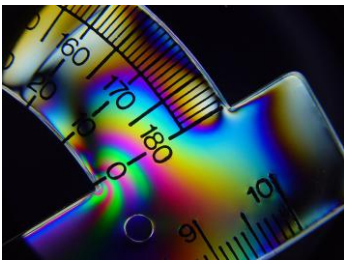

- From 50264-200 (<https://www.fisica.com/ati>) that were used on SPG Fast Marx, Lockheed Martin PulseRad 428 and Honeywell 430, WSMR PGS, Crane SPG, we introduced a series of modifications for QE switches, aimed to optimize the mechanical and electrical characteristics:
 - Improve seals
 - Electrode profile was optimized to reduce electric field enhancements
 - Increased the mechanical strength of interior components
 - New procedure to inspect, assemble and leak test the switches

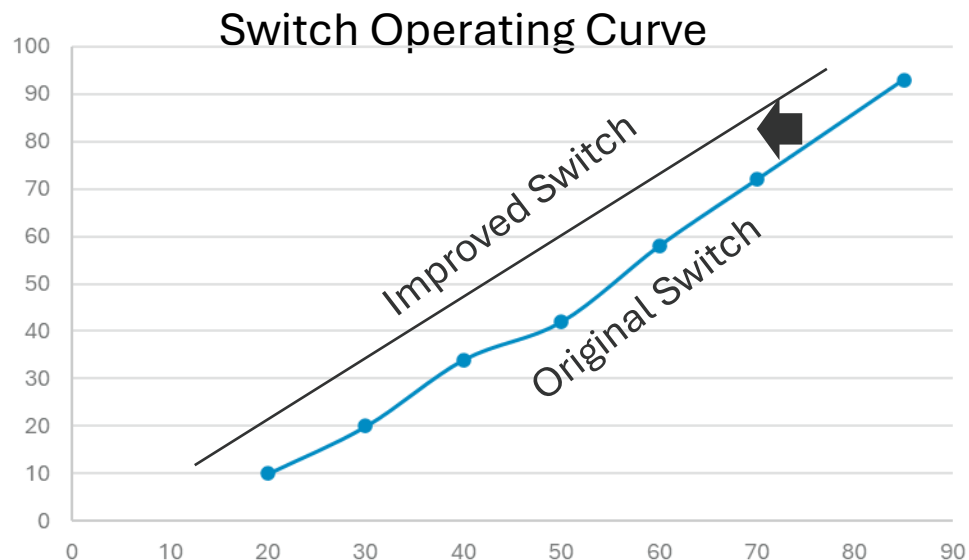

- Switch uses dry Air gas (Ultra Zero) to operate
- It was estimated that during a full charge shot at QE the total volume needed is ~ 90 cu ft... 1 gas cylinder per shot
- Improved the input and output manifold designs for more effective gas flow through the switch immediately after operation to increase switch lifetime
- Pressure/voltage operational curve was improved after implementing design modifications

Development of the Fast Marx Technology: CCM in Eaglet 2

FISICA 200-kV switches

- Coulomb transfer is a critical characteristic of switch lifetime and performance. 50264 experimental data shows a peak of ~100 mC without failure.



Bipolar= ringing
 $Q = \int |I| dt$

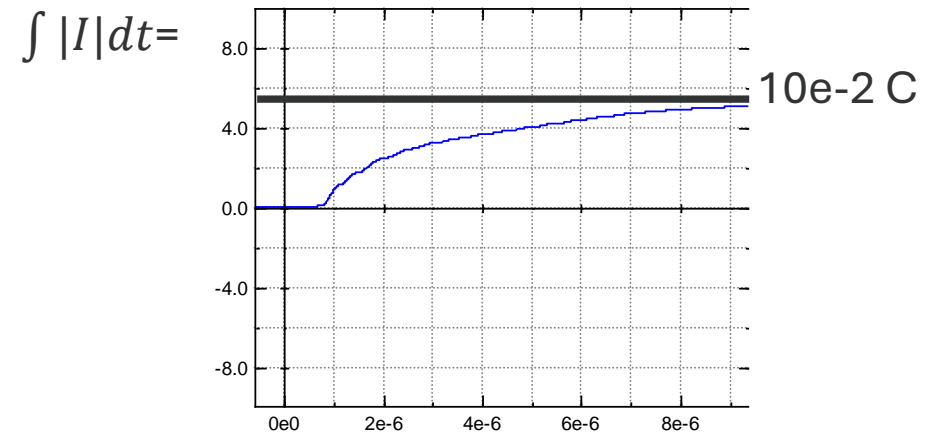
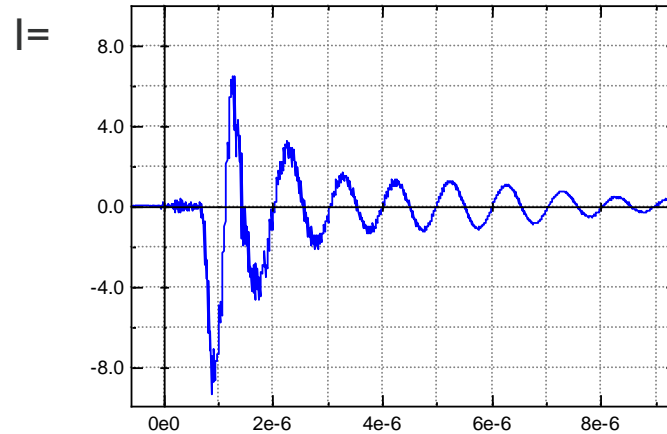

- Shorted shot with long time ringing stresses the switch for larger coulomb transfer

Oil quality

- Breakdown Voltage for the insulating oil becomes a critical parameter in the Fast Marx operation
- Internal criteria: oil quality to be >38kV/0.1” during standard operation based on ASTM standards
- FISICA developed its own Vacuum dehydrator to increase the quality of the oil without increasing its temperature. This translate in the high advantage to be able to process oil directly in the Marx tank.

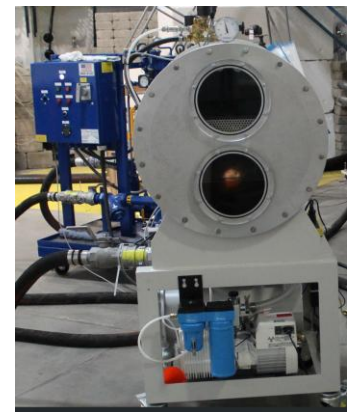

➤ Development of the Fast Marx Technology: CCM in Eaglet 2

Eaglet 2 - CCM Simulation and testing into Resistive Load

- Detailed Castle code with trigger signals imported from Stella, charge on CCM negative polarity into two parallel 15Ω loads

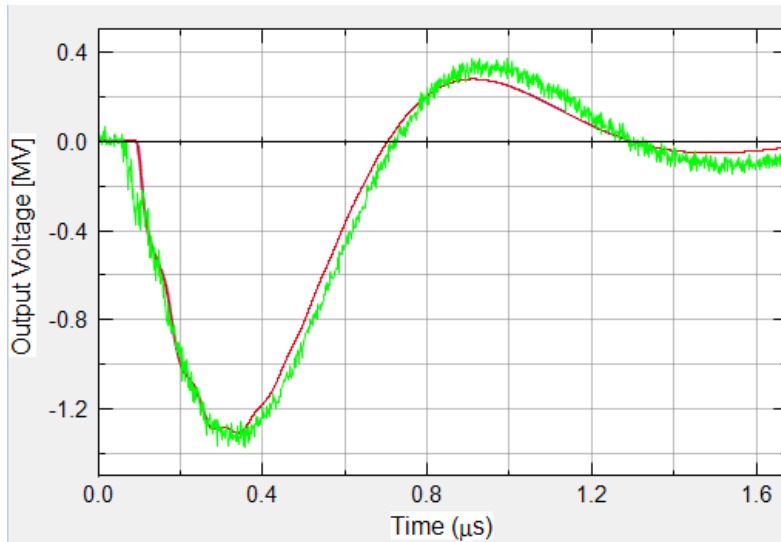

Green: experimental data
Red + blue: simulated data

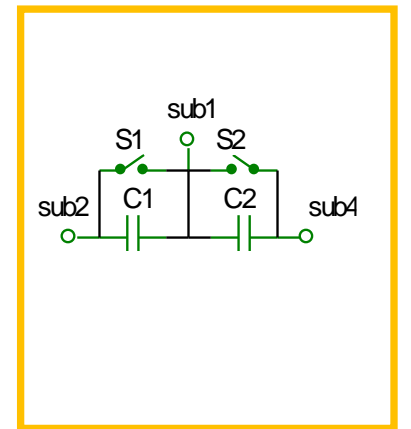
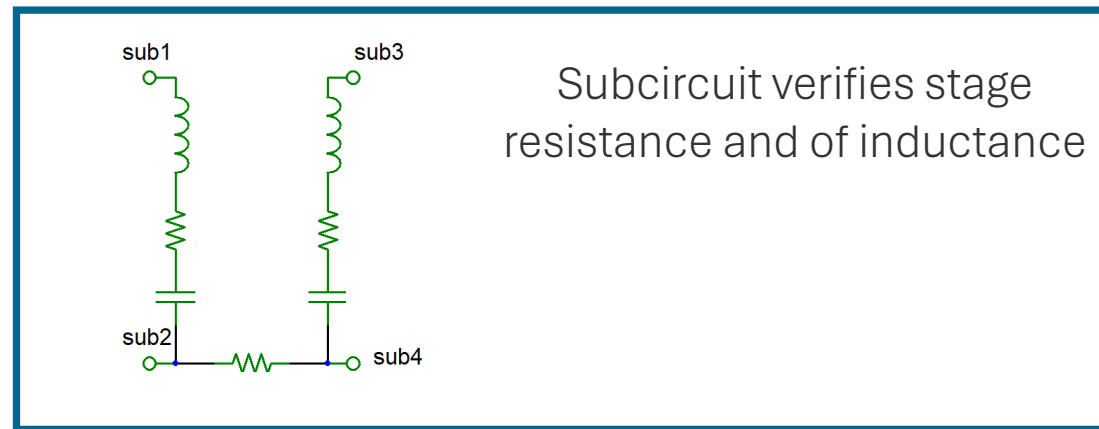

Development of the Fast Marx Technology:

Fast Marx technology has been developed by FISICA (formerly Maxwell Physics International) from the 90s:

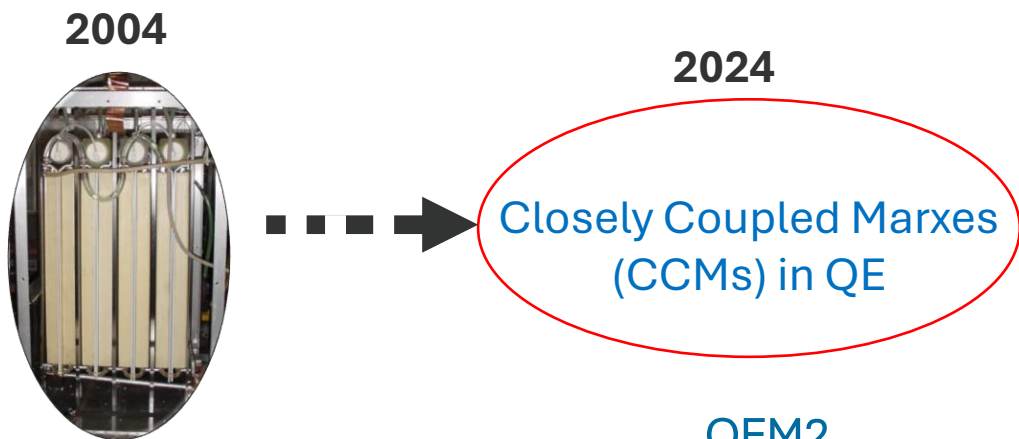

Fast Marx Research

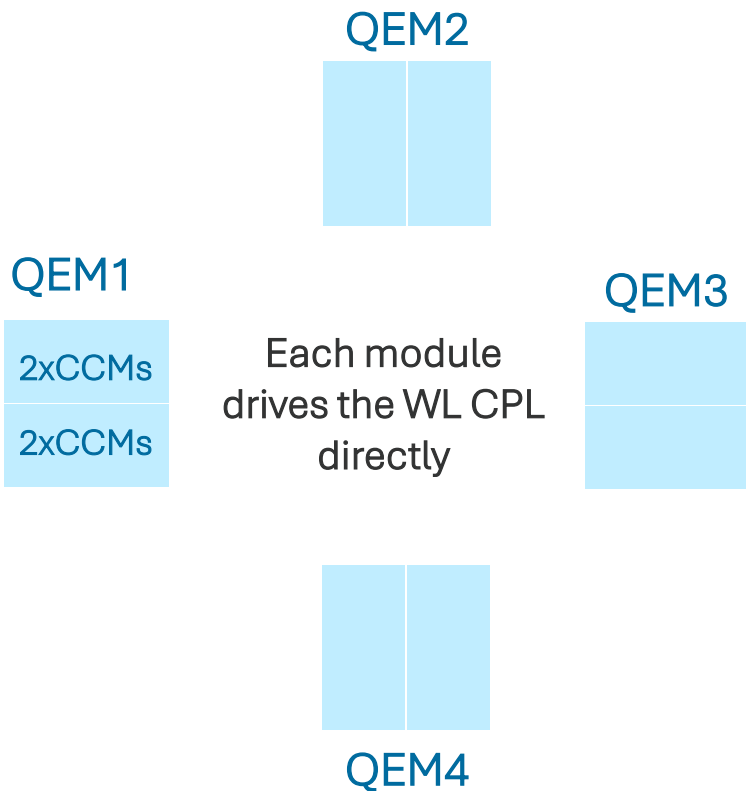

	# of sub-Marxes	Energy stored
Marx Tank	4 sub-Marxes (2 CCMs)	184.96 kJ
Module	8 sub-Marxes	369.92 kJ
½ QE	16 sub-Marxes	739.84 kJ
QE	32 sub-Marxes	1479.68 kJ

QE is a ~1.5 MJ or a ~ 9.25 TW machine

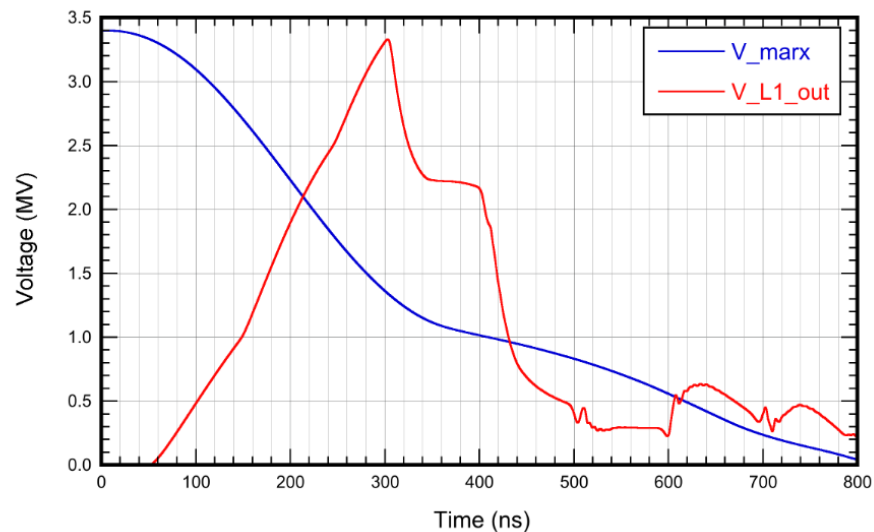

Screamer calculations of Marx voltage and CPL voltage for ½ of QE

➤ Quad Eagle Module testing and Simulations

Each Module was tested independently. Circuit simulation were used to understand experimental results

- This Castle model includes parameters for stage resistance and inductance found from matching simple circuit to short circuit shots on FMT and EAGLET 1
- QEM1 Castle model has been benchmarked to Screamer and CST
- QEM1 circuit simulation uses:
 - 3 lumped CCM models
 - 1 split CCM model with closely coupled sub-Marxes
 - Model allows for switch triggering based on voltage inputs or time based triggering
 - detailed triggering model, based on trigger barrel
 - transmission line circuit elements at QEM1 waterline

➤ Quad Eagle Module testing and Simulations

- Comparing **simulation** (time-based triggering) and **experimental** signals in a prefire shot during QEM1 testing.
 - Pre-fire was experimentally induced dropping switches pressure in CCM2U
 - When large timing difference between non closely coupled Marxes occurs the voltage reversal can damage caps when the outputs are tied together

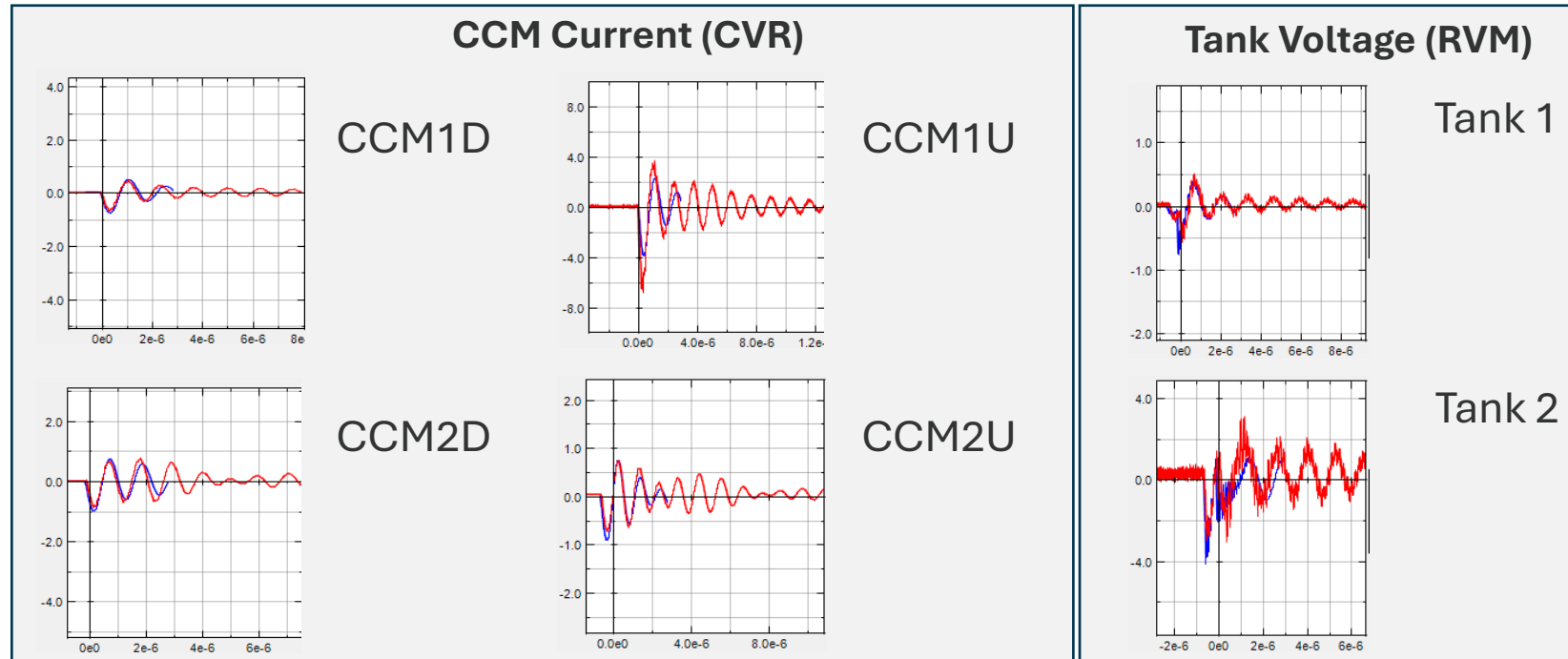

- Timing between first and last CCM firing was 600ns on this shot
- Worst case – no coupling between CCMs and still got good agreement between model and experimental results
- This type of test helps to determine maximum non-damaging charge voltages and timing differences

➤ Quad Eagle Module testing and Simulations

- Mitigation of reversal. This simulation was used to understand how to mitigate Capacitors reversal at all charge voltages, in case of the worst-case scenario of Pre-fire in one CCM and short far downstream.
- Several simulations were performed varying:
 - Diverter location
 - Diverter Switch gap
 - Number of diverter used
 - Resistive Values for Diverters
 - Prefire timing (up to 130 ns delay between first and other CCMs)
 - Marx charge

Reversal swing on CCMs end Capacitors In case of one CCM pre firing and the other three CCMs going 130ns later

Diverters in WL:

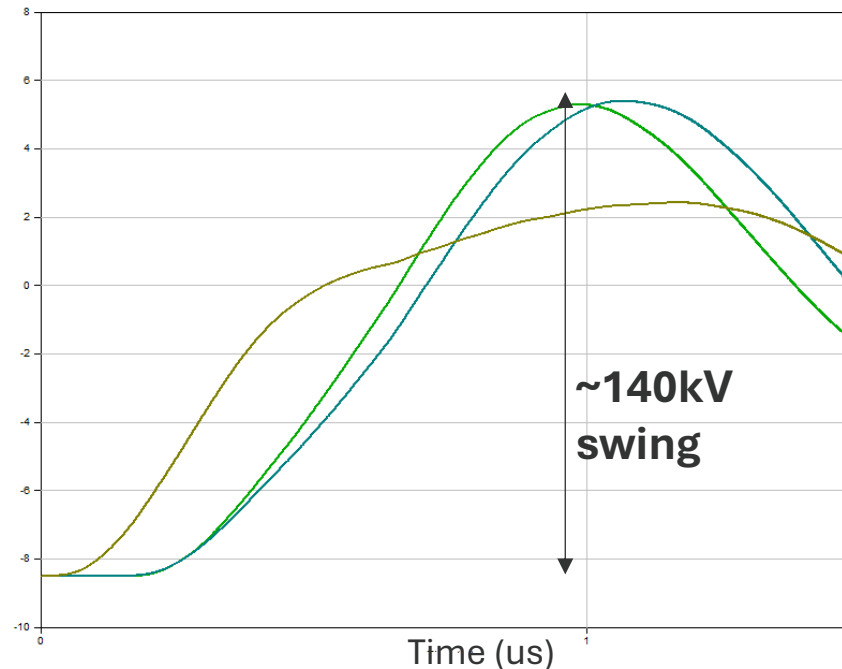

...higher than the reversal value recommended by the manufacturer: 120kV

➤ Quad Eagle Module testing and Simulations

Clamp/Diverter in oil Tank: an effective way to reduce reversal on Capacitors and protect the CCM during pre-fire

- 4 div in oil with one CCM Pre-firing and the other 3 going after:

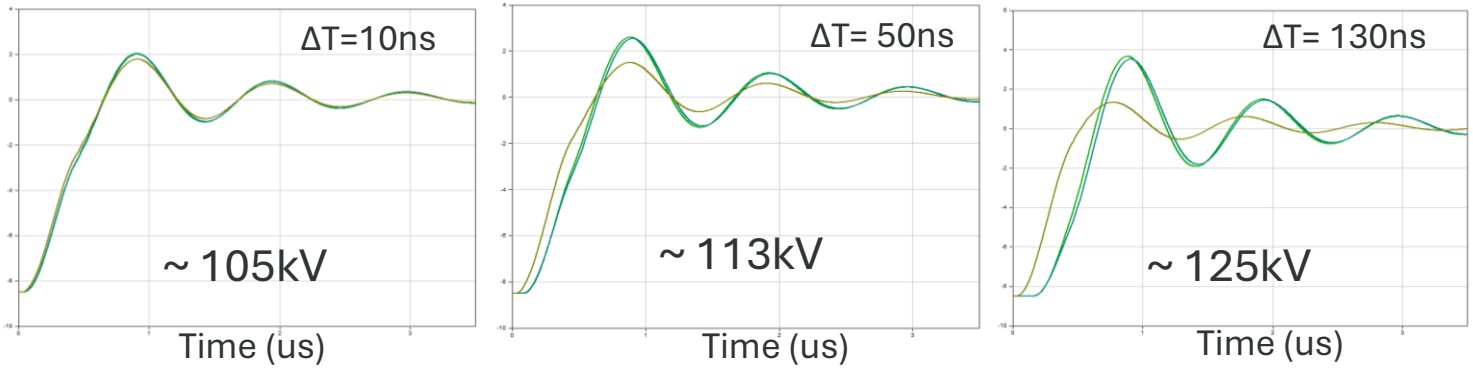

If time between CCMs firing increase, then the reversal swing on Capacitors get worse.

- all CCM firing at the same time:

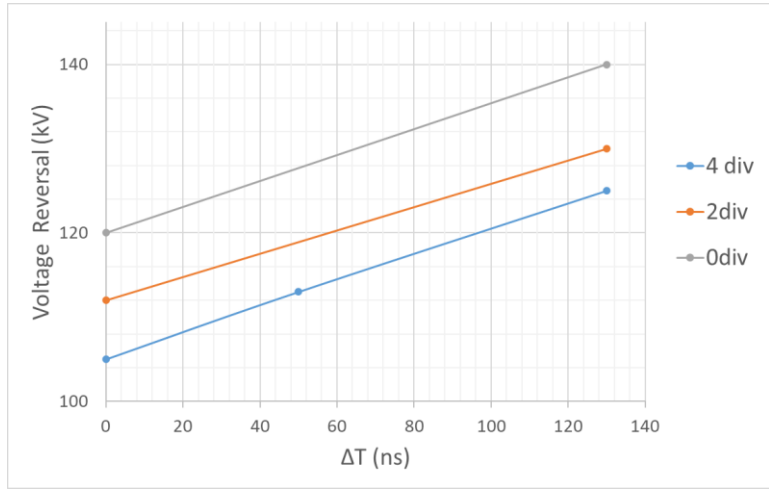
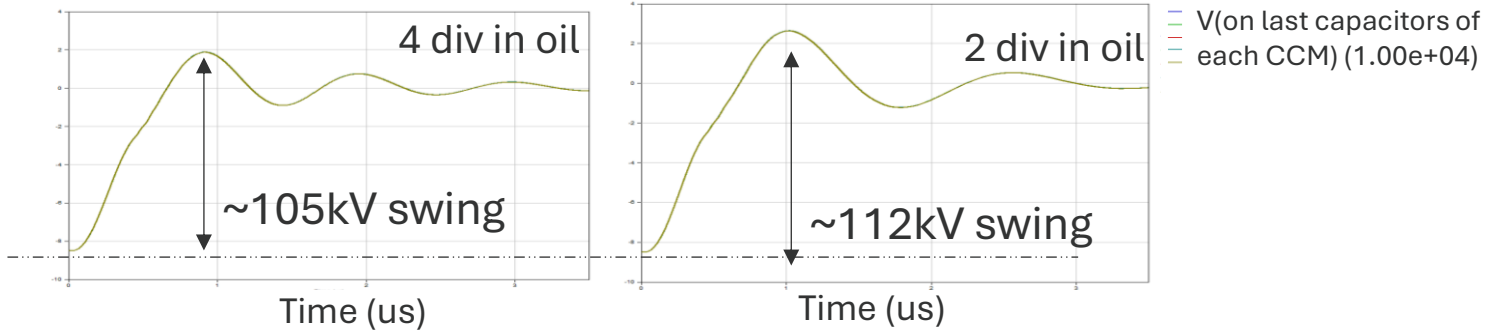

Presence of Diverters in oil, ideally one for each CCM, help lowering the reversal on Capacitors. In the case of no diverter in oil we do have ~120kV swing when all CCM are firing at the same time.

➤ Quad Eagle Module testing and Simulations

Clamp/Diverter Mechanical Design

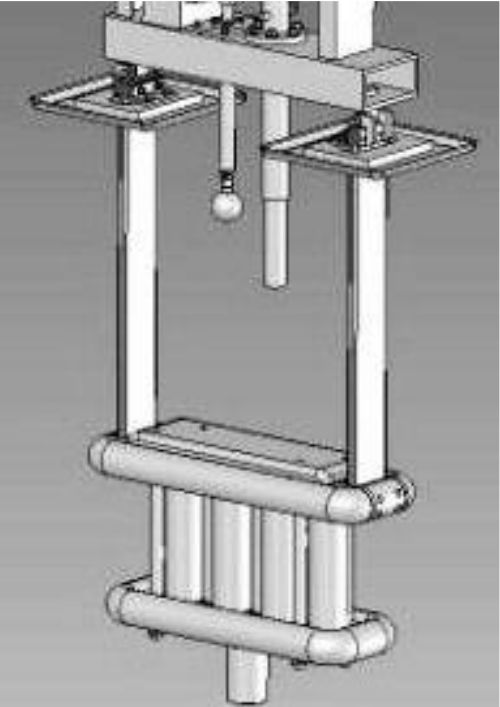

"PERFORMANCE OF SELF-CLOSING DIVERTER SWITCHES FOR ZR/Z20 MARX AND INTERMEDIATE STORE PROTECTION", Conference paper July 2005, DOI: 10.1109/PPC.2005.300535

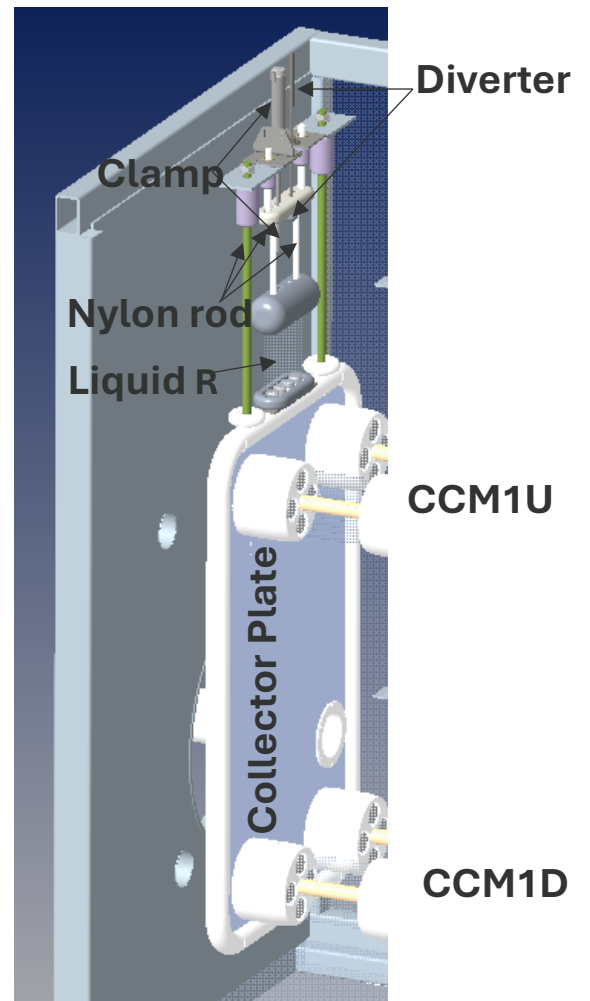

Resistor is designed to handle 352kJ from all 4 sub-Marxes.

Clamp/Diverter E-static Analysis (CST)

Electrostatic simulations were run for 2 cases:

- Clamp closed

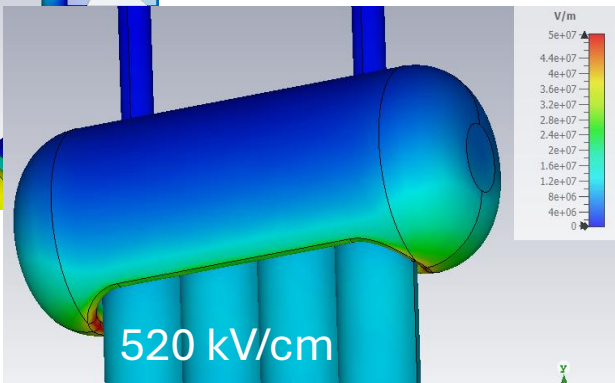
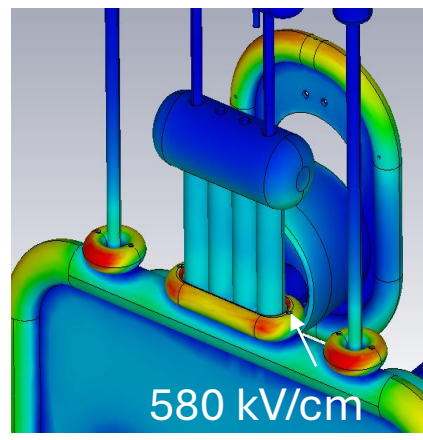

- Clamp Opened (diverter gap adjusted from 0 "to 6")

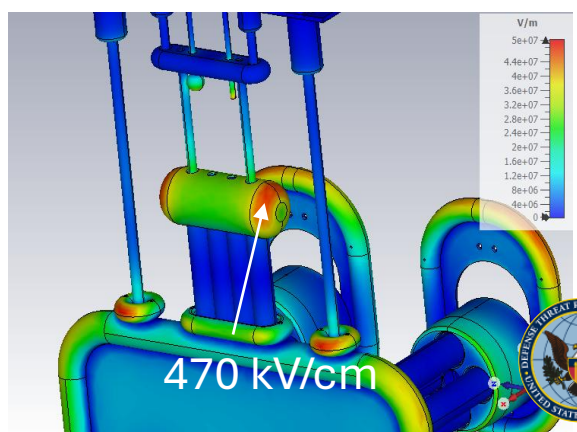

➤ Quad Eagle Module testing and Simulations

Experimental result – effects of the clamp during testing

- RVM 3 and 4 are the Voltage signals from the Voltage monitor on the collector plate of Tank 3 and Tank 4.
- Up and Down CCMs are Closely coupled in each Tank though a cable connecting the field shapers on the 3rd stage.
- One Clamp/Div system is installed in each Tank

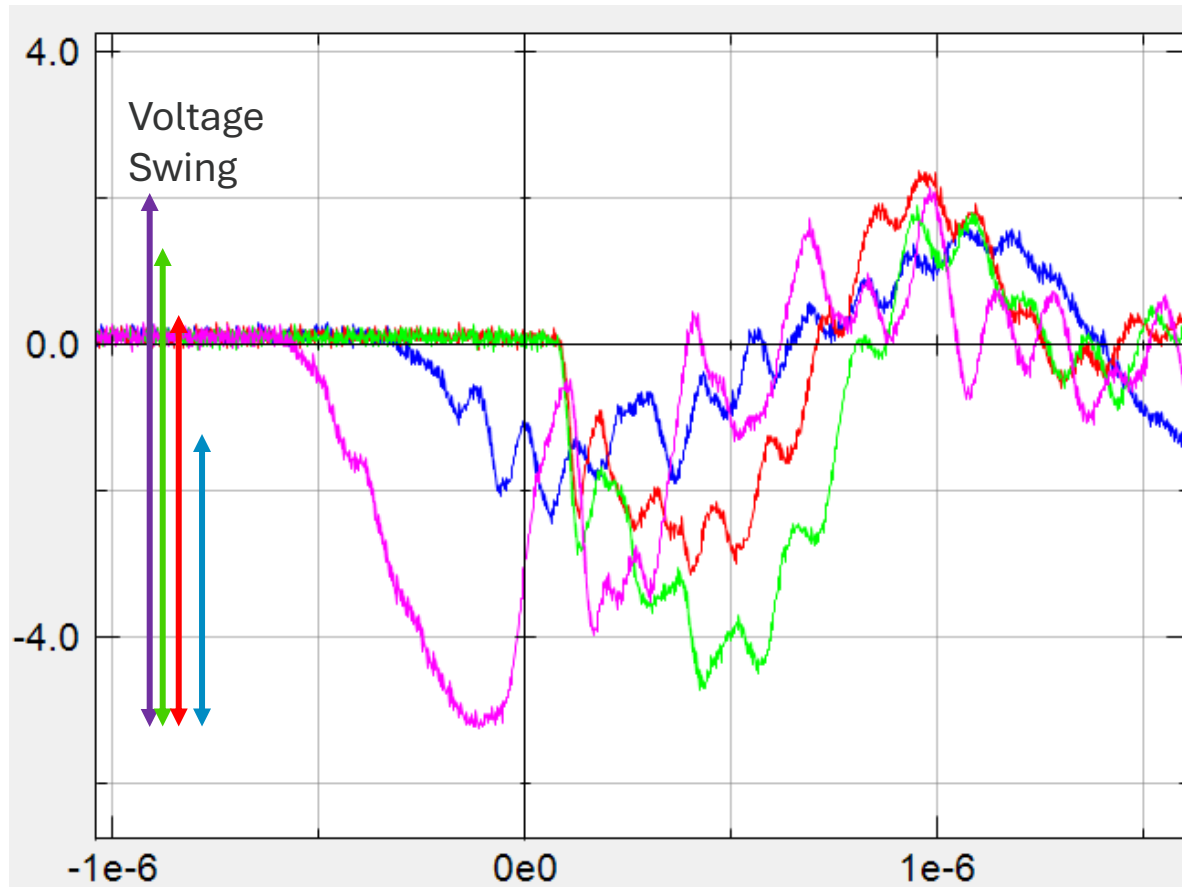

➤ QE Trigger System:

- QE has four modules
- Each Module is triggered by a single Secondary Barrel which has 8 output cables
- The four Secondary Barrels are triggered by a Main Barrel which has 4 output cables
- The Main Barrel is triggered by a FISICA TG100
- Trigger Barrels are oil insulated with 50264 air switches
- Each CCM uses two output trigger cables from a secondary barrel (One for each of the two subMarxes)
- Each trigger cable is connected to the subMarx through a blocking Capacitor.
- During high voltage DC charge of the output cables the blocking cap keeps voltage off of the switches but during fast discharge the impulse can go through.
- Each blocking cap is connected to two trigger resistor chains for redundancy.
- We do have two version of the Switches (with or without the UV irradiation pin). Switches on the last 14 stages are triggered by overvoltage during the erection of the Marx

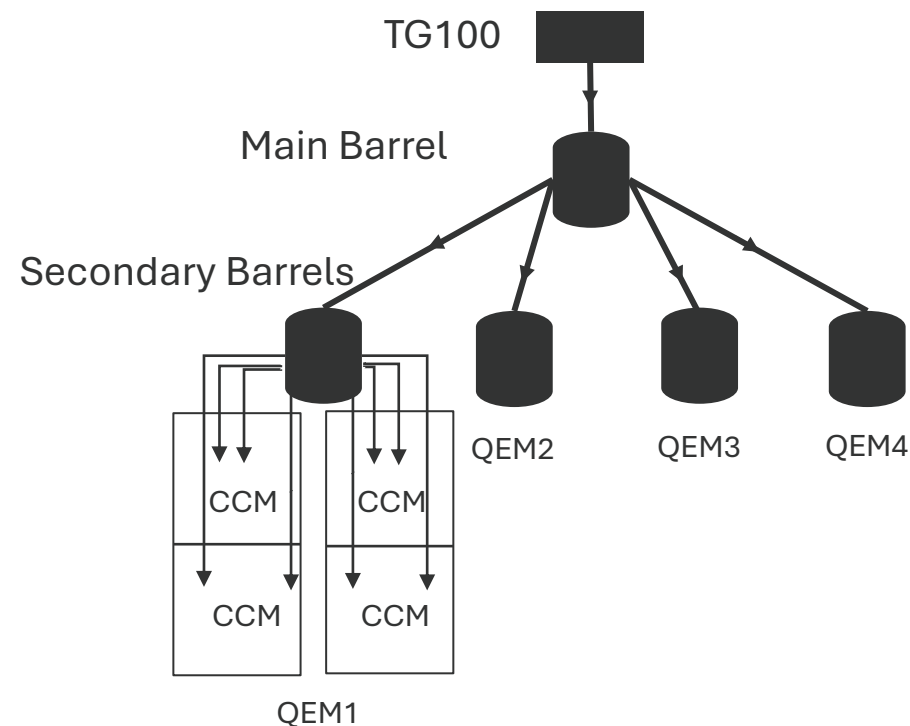

➤ Conclusions and future outlook:

1. Development of fast Marx is the result of a deep and thorough understanding of insulating oil, capacitors and gas switches.
2. Combinations of fast Marxes CCMs can be used to develop high voltage by increasing number of stages or high current machine by developing them in parallel to create terawatt facilities. Tell us your requirements and we will build it for you!
3. Detailed simulations show not only initial pulses but reflections and high frequency perturbations in order to design machines that protect components and deliver power and energy downstream
4. Once QE is fully qualified, our main objective will be ensuring outstanding customer Testing.

➤ FISICA – DTRA WCF Simulators:

Short Pulse Gamma (SPG)



- Gamma and electron beam simulator
- Produces up to 20 shots/day
- Short pulse is optimized for minimum dose to satellite electronics with high dose rate
- Low jitter command fire capable

Pulserad 1150

- Longer pulse gamma ray simulator
- Produces up to 15 shots/day
- Can be operated in a variable pulse width mode
- Also has a high energy electron beam mode for high dose rate materials testing

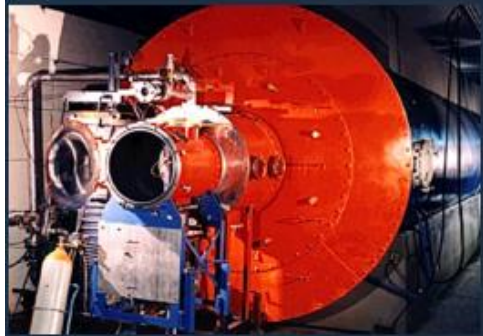

Modular Bremsstrahlung Source (MBS)



- High-fidelity, warm X-ray simulator
- Produces up to 12 shots/hour
- Radiation pulse width and rise time are adjustable over limited ranges

PITHON



- Simulates warm and hot X-rays
- Produces up to 3 shots/day
- Electron beam or an ion beam mode also available

Quad Eagle

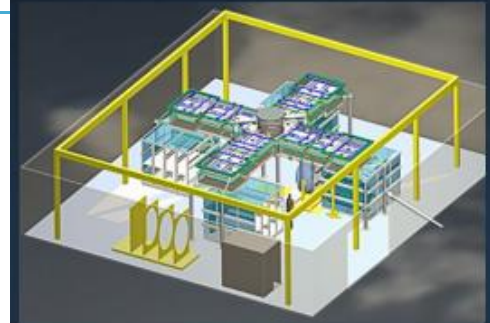

- Largest simulator at the DTRA West Coast Facility
- Nominal operation is 2 shots/day
- Very high peak electrical power
- High dose rate over a large range of test areas
- Spectral range capabilities from UV to hot X-rays
- Electron beam capabilities
- Low command fire jitter

Contact: tyler.daykin@fisca.com or barbara.whitton@fisca.com

For testing needs